

Catalog Number
Notes
Type



ILLUMINATION

- Long-lasting, efficient, ultra-bright white LED lamp heads.
- 1.5 watt (12 LEDs x 0.125 watt) per head.
- High performance chrome-plated metalized reflector and plastic lens for optimal light distribution.
- Adjustable LED lamp heads provide optimal center-to-center spacing.

ELECTRICAL

- Dual 120/277 voltage.
- Charge rate/power "ON" LED indicator light and push-to-test switch for mandated code compliance testing.
- LVD (low voltage disconnect) prevents battery from deep discharge.
- 6V sealed lead acid, maintenance-free, rechargeable battery.
- Runs up to eight hours without remote heads
- Internal solid-state transfer switch automatically connects the internal battery to the LED lamp heads for minimum 90-minute emergency illumination.
- Fully automatic solid-state, two rate charger initiates battery charging to recharge a discharged battery in 24 hours.

MOUNTING

- Universal knockout pattern on back plate for wall mount.
- Side and top knockouts for conduit feed applications.

HOUSING

- Durable 20-gauge steel construction in white or black finish.
- Injection-molded engineering grade high-impact thermoplastic lamp heads to match housing finish.

WARRANTY / LISTING

- Five year warranty on all electronics and housing. Battery prorated for two years.
- UL Listed for damp locations (20°C - 50°C) standard.
- Meets UL9024, NFPA 101 Life Safety Code, NEC, OSHA, Local and State Codes.

PERFORMANCE

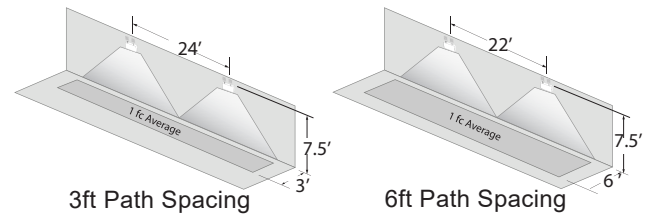

DIMENSIONS

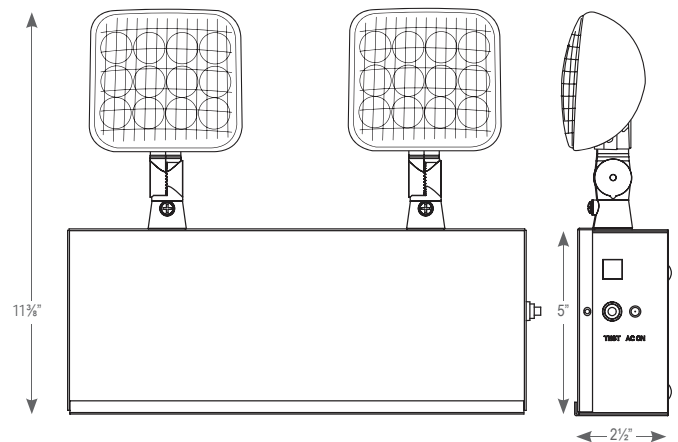

ORDERING INFORMATION

Sample Part Number: **SUL627**

MODEL	VOLTAGE		WATTS		HOUSING COLOR	
SUL	6	6 Volt	27	27 Watts	(blank)	White
					B	Black